

Design, Analysis and Fabrication of a Vaporizing Liquid Micro-Thruster

Juergen Mueller¹, William C. Tang², Andrew P. Wallace³, Wen Li⁴,
David Bame⁵, Indrani Chakraborty⁶, and Russel Lawton⁷

*Jet Propulsion Laboratory
California Institute of Technology
Pasadena, CA 91109*

The design and fabrication of a newly proposed vaporizing liquid micro-thruster concept is described. The intended purpose of this thruster concept is for use as an attitude control device on new generations of very small spacecraft envisioned by the National Aeronautics and Space Administration (NASA), ranging in mass between 1 - 20 kg. The vaporizing liquid micro-thruster concept heavily relies on microfabrication techniques to achieve order of magnitude reductions in both size and weight to fit the design limits of the envisioned microspacecraft environment. Attention was focused on thermal design aspects to limit power requirements to values less than 5 W, requiring specially contoured substrate shapes and packaging of the thruster chip. Since the thruster concept consists of a bonded structure and will be pressurized internally, bond strength tests were performed. Anodic bonds were found to be more than sufficient to maintain the current design internal pressures of 340 kPa. Several chips were fabricated and are currently awaiting performance testing.

Introduction

Background and Significance

Within the National Aeronautics and Space Administration (NASA), a research and development initiative is currently underway to investigate the feasibility of microspacecraft in the 1-20 kg class. The motivation behind this development is the desire to reduce launch masses in order to reduce mission costs and greatly increase launch rates. Launch costs for a typical interplanetary mission may be as high as 30% of the overall mission cost and these costs may be reduced significantly as a result of substantially reduced spacecraft masses. In addition, microspacecraft mission scenarios may be envisioned where, rather than launching a single large spacecraft, the mission is accomplished by a fleet of several smaller microspacecraft, with the scientific payload distributed among the micro-craft to reduce mission risk. Loss of one microspacecraft would not eliminate the entire mission.

Building microspacecraft in the 1-20 kg class, however, will necessitate the miniaturization of every subsystem in order to maintain the high degree of onboard capability required to ensure an acceptable scientific return for the mission. One of the sub-systems that will be included to undergo such a reduction in weight and size is propulsion. Although in the past many very small spacecraft have lacked propulsion systems altogether, future microspacecraft will likely require significant propulsion capability in order to provide a high degree of maneuverability and capability. Of these, attitude control will be required for interplanetary spacecraft to point the spacecraft for observation or communication, establishing a need for very small attitude control thrusters.

Micropropulsion Technology Needs

In a companion paper currently available thruster hardware was surveyed in view of its applicability to microspacecraft missions¹. This hardware was evaluated based on a set of representative mission requirements obtained from a micropropulsion workshop recently held at the Jet Propulsion Laboratory (JPL)². Table 1 summarizes the attitude control requirements for several microspacecraft classes, based on the findings presented in Refs 1 and 2. As can be noted, impulse bit requirements are very small for these types of spacecraft. Currently, the smallest available thrusters are of the cold gas type and provide impulse bits as

¹Member of Technical Staff, Advanced Propulsion Technology Group, Member AIAA

²Group Supervisor, MEMS Group.

● ³Member of Technical Staff, MEMS Group

⁴Member of Technical Staff, Reliability Engineering Group

⁵Member of Technical Staff, Propulsion Flight Systems Group

small as about 10^{+4}Ns^1 . Even these values are still larger than the I-bit values required (see Table 1). In addition, cold gas systems suffer from other disadvantages, among them leakage concerns and heavy and bulky tankage due to the requirement of high-pressure propellant storage'. Other thruster types, such as Pulsed Plasma Thrusters (PPT) have been developed and are subject to further miniaturization. However, the PPT concept, even though able to provide the minimum impulse bit requirements, cannot deliver the required minimum thrust levels to perform the desired slew rates'.

As a result of the survey performed in Ref. 1, a need for a very small attitude control thruster, able to provide impulse bits of 10^{+5}Ns or less, at minimum thrust levels of several **mN** or less was identified. In addition to delivering these thruster performances, a high degree of miniaturization will be required in order to be able to install multiple attitude control thruster clusters around a **microspacecraft** bus with characteristic length scales of a mere 10-30 cm.

Vaporizing Liquid Micro-Thruster Concept

A new **micro-thruster** concept was introduced at the Jet Propulsion Laboratory specifically with **microspacecraft** applications in mind and is the subject of this paper. This thruster, termed a "Vaporizing Liquid Micro-Thruster (VLM)" or **micro-resistojet**, relies heavily on new **microfabrication (MEMS - Microelectromechanical Systems)** techniques to achieve order-of-magnitude reductions in both volume and mass. In this thruster concept, a suitable liquid propellant (such as ammonia or hydrazine, early laboratory tests will involve water) is vaporized in a thin-film deposited heater arrangement and the resulting propellant vapor is expanded through a **micro-nozzle** to produce **thrust**³. In this paper, design, analysis and fabrication of this thruster type will be discussed.

Approach

The vaporizing liquid micro-thruster (VLM) concept is one of several **micropropulsion** concepts currently

under investigation at JPL as part of a larger activity to miniaturize spacecraft subsystems to achieve the mass and volume reductions outlined above (see Table 1). The vaporizing liquid micro-thruster constitutes one of the first thruster concepts specifically designed for **microspacecraft** applications. The VLM concept is representative of JPL's approach to **micropropulsion**, consisting of the conduction of **high-risk/high** pay-off research and development in this field through the use of advanced **microfabrication** technologies, such as MEMS, to achieve order of magnitude reductions in size and weight, as well as I-bit and thrust capability. The **micropropulsion** concepts under investigation at JPL, including the VLM device discussed here, therefore have to be considered as advanced **micropropulsion** options, still requiring a significant amount of research and development over the coming years. Near-term goals for the vaporizing liquid and **other**¹ thruster concepts therefore is to evaluate and demonstrate the feasibility of these thruster concepts for use as a **micro-thruster** option. If successful, however, these thruster concepts may be enabling to many **microspacecraft** missions within the mass and volume constraints discussed above, and may significantly benefit others through propulsion system weight and mass reductions.

The VLM concept is illustrated in Fig. 1. The thruster consists of three major components: two **microfabricated**, identical silicon wafers and one Pyrex spacer, sandwiched between the two silicon wafers. Liquid propellant, pressure-fed into the thruster assembly, enters the chip through an entrance hole through one of the silicon chips. It then flows through a channel that has been machined into the Pyrex. Top and bottom surfaces of this channel are formed by the two silicon wafers, featuring the thin-film heaters. These heaters are made from **doped polysilicon** (as opposed to the single crystal silicon forming the substrate wafers) or metal (Au, Al), thin-film deposited onto the silicon substrate. A photo of one of these heater strips is shown in Fig. 2. The heater strip is connected to two contact pads through which electric power is applied.

As the propellant flows across the heaters, it is vaporized and the vapor is expanded through a nozzle machined into the second silicon wafer. The nozzle has

Table 1: Representative Attitude Control Requirements for **Microspacecraft**

S/C Mass (kg)	S/C Dimension" (m)	Ibit (mNs)	T _{min} (mN)
20	0.4	0.013	4.65
10	0.3	0.005	1.75
1	0.1	0.0002	0.06

" Assume cubical spacecraft shape

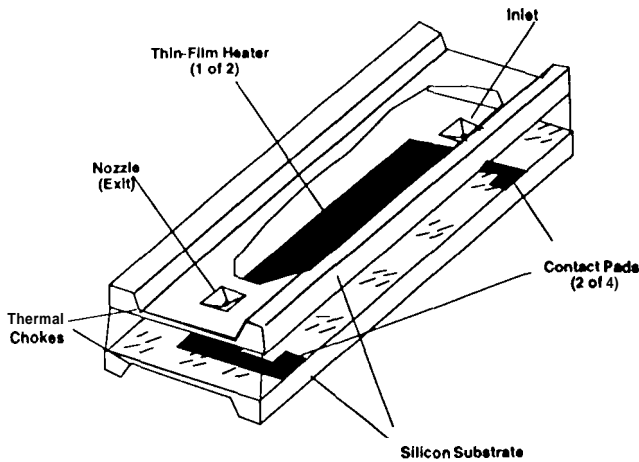

Fig. 1: Concept of the Vaporizing Liquid Micro-Thruster

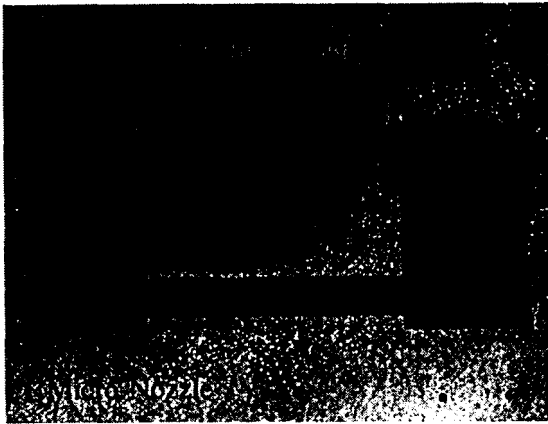

Fig.2: VLM Heater Detail

converging and diverging sections and has a unique square contour (see Fig. 3). The peculiar shape of the nozzle is due to the fabrication process. Square nozzles, such as the ones shown in Fig. 3, can be machined easily into silicon using anisotropic etchants. These etchants (e.g. KOH) etch different crystallographic planes of the silicon crystal structure to different degrees. The nozzle walls in Fig. 3 are comprised of $\{111\}$ planes, etching the slowest and thus being left standing longest. The resulting nozzle cone angle is about 70° and fixed by the crystal properties of silicon. Nozzle shapes like these may not yield optimal performances due to the large diverging angles, however, performance optimization was not a near-term goal for the first generation of these thruster chips. For fabrication reasons, both silicon wafers are identical. Thus, the thruster assembly features a converging-diverging nozzle as an entrance hole although the nozzle shape will have no effect

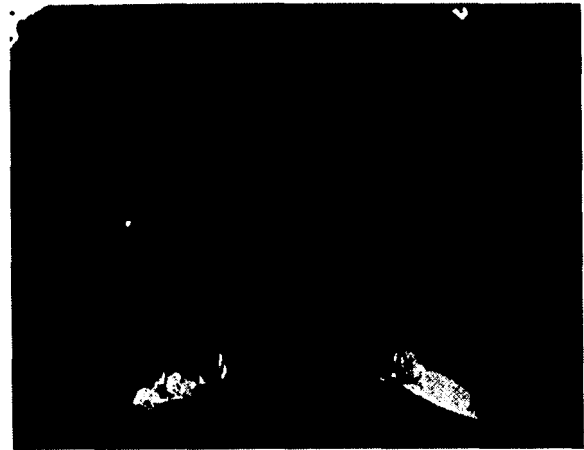

Fig. 3: Electron Microscope Scan of VLM Nozzle

on the liquid (incompressible) propellant flow at this location.

The silicon substrate design shown in Fig. 2 is noteworthy. In order to reduce heat losses into the structure due to the high thermal conductivity of silicon (about 150 W/mK), a recess was manufactured into the silicon substrate just underneath the heater strips. The resulting “bridge” structure thus forms thermal chokes near the edges of the heater strips, reducing heat conduction away from the heaters⁶.

The vaporizing liquid micro-thruster concept was selected because of the following design considerations:

(a) *Reduced Leakage Concerns:* Since the vaporizing liquid micro-thruster is a phase-change thruster concept, where propellant is stored as a liquid and vaporized inside the thruster, it significantly reduces the leakage concerns that plague cold gas thruster designs. Liquid leak rates are orders of magnitude lower due to higher liquid viscosities than those found for gaseous propellants, thus reducing propellant losses.

(b) *Simplicity:* Although the VLM concept, as any micromachined thruster concept, faces significant feasibility issues that need to be addressed through substantial development work over the coming years, it is inherently simple, featuring no complex moving parts (micro-pumps, turbines, etc.), and relying only on a relatively simple heat transfer mechanism, rather than complex combustion or plasma generation schemes.

(c) *Refinability:* As a consequence of the simplicity of the concept, the VLM is anticipated to be a very reliable thruster

technology. Chamber pressures will be chosen to lead to very benign conditions for the MEMS materials involved (silicon, polysilicon, Pyrex). Although silicon exhibits considerable yield strengths, approaching that of steel⁴, it is a non-ductile material, and may be prone to failure due to cycling under high-pressure, high-temperature conditions. Care was taken in selecting the VLM operating conditions to avoid any problems in this regard as far as possible. Internal design pressures were set preliminarily at 340 kPa .

(d) *Flexibility of Use:* A pressure-fed VLM thruster device would not experience any limitations with respect to duty-cycle performances or duration of thruster firings, as, for example, a cold gas ammonia thruster would^{1,5}. In the latter thruster concept, ammonia is stored as a liquid propellant. Due to the high vapor pressure of ammonia at relatively low temperature (224 kPa at -18 psia)^{1,5}, boil-off from the tank could be expanded through a cold gas thruster to generate thrust. Although a very attractive concept for microspacecraft use, thruster duty cycles may be limited, or long thruster firings may be difficult to achieve due to the limited evaporation rates of ammonia in an unheated tank. The VLM concept would avoid these constraints.

Targeted performance values are expected to be around 100 - 150 sec depending on the propellant used and heater temperatures achieved. These values may not appear high, however, are thought to be sufficient for attitude control purposes. Attitude control propellant requirements are typically low, representing merely a few percent of the total spacecraft weight⁷, providing little opportunity for substantial spacecraft mass reductions, even when using much higher performing engine technology, if available.

The VLM thruster concept will face several design challenges that will need to be addressed in its development program. Among these are the demonstration of complete vaporization of the propellant, low power consumption compatible with the microspacecraft environment, and the demonstration of sufficient thruster life capability, in particular with respect to thruster cycling, essential in its envisioned use as an attitude control thruster. In the following chapters, the steps taken in order to address these challenges will be outlined. They will include thermal and structural finite element analysis of the VLM structure, demonstration of sufficient pressure handling capability of the anodic bond between the silicon and Pyrex sections of the thruster chip, and, finally, fabrication of the chip.

Thermal and Structural FEA of Thruster Body

Thermal and structural finite element calculations were performed to better understand the heat loss mechanisms and associated structural considerations involved in the thruster design. As noted above, a recess was machined into the silicon in order to reduce heat losses into the structure by creating thermal chokes near the edges of the heater strips. Since conductive heat losses may be written as

$$q = \Delta T \frac{l}{kA}$$

with l , k and A being defined as length, thermal conductivity and area, and ΔT as temperature difference. Heat losses can therefore be reduced by decreasing the cross sectional area through which heat flux occurs and by increasing the heat conductive path. The "bridge" configuration of the heater substrate assembly accomplishes both. However, increasing l , or the "length" of the bridge will make the resulting structure less rigid under pressure loading caused by the vaporization process and feed pressures applied to the thruster. Therefore, a finite element analysis was undertaken to model various thruster structures numerically in order to determine an optimum design solution.

The finite element analysis is described in detail by Wallace⁶. Briefly, a Patran[®] finite element package was used to model the geometry of the problem and P3 Thermal[®] and AdvancedFEA[®] solvers were employed to perform the thermal and structural analysis, respectively. All calculations were two-dimensional, assuming that the length of the recesses far exceeding their widths (compare with Fig. 1), thus minimizing edge effects. In addition, perfect symmetry was assumed in these calculations with respect to the temperature fields. This is an idealization, since cold liquid entering the thruster at one end and hot vapor exiting the thruster at the other end will lead to some temperature differences. However, these calculations have to be viewed in the context of their intended use, i.e. provide a basis for intelligent decision making in the designing process of the vaporizing liquid micro-thruster through comparative analysis and, as such, the symmetry assumptions made above appear acceptable at this point.

Figure 4 show the results of a typical finite element run for a 125 C surface temperature⁶. The steep temperature gradients in the areas of the thermal chokes can be seen. Table 2 summarizes thermal and structural results by listing the effective thermal resistance (i.e. the quotient l/kA in the equation above) of the structure and the maximum stresses found in the "bridge" for different widths and thicknesses of the "bridge"⁶. As can be seen from Table

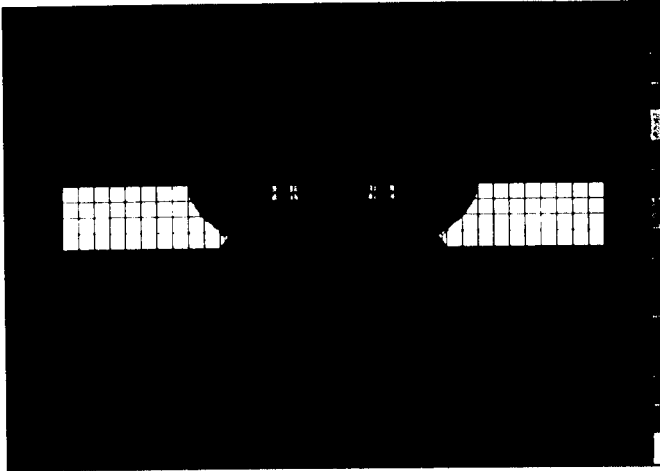

Fig. 3: Example Run of Thermal Finite Element Calculation

2, “bridge” structures 1000 micron wide and 100 micron thick will lead to a reduction in power losses by a factor of about four, while still maintaining low maximum stresses of only 8 MPa. Flexural strengths for silicon vary between values of about 60 - 580 MPa⁶. The large differences between the flexural strength values is likely a result of different crystal orientations of the silicon which unfortunately is frequently not reported in the literature⁶. However, even assuming a conservative value of 60 MPa, the maximum stresses in the above mentioned case stay well within the allowable range. Note, however, that absolute power values required to raise heater temperatures to 125 C, for example, are large. According to the equation above, a thermal resistance of 3.8 C/W for the case of a 1000 micron wide, 100 micron thick “bridge”, and a boundary condition of 20 C at the bottom of the silicon substrate (assumed spacecraft environmental temperature), the required heater input power per heater would be $(125 - 20) C / 3.8 C/W = 27 W$, or about 54 W total! Even though this represents a significant reduction from over 150 W per heater or 300 total for an uncountoured substrate (see Table 2 and equation above), the achieved reduction in heat losses is insufficient and power values would be incompatible with the

microspacecraft environment. Higher heat reductions are possible, resulting in estimated power requirements of 15 W per heater if the bridge thickness was reduced to 50 micron. However, maximum stress levels occurring in the structure in this case would reach critical stress levels in the silicon.

The option of depositing a thermally insulating oxide layer between the silicon substrate and the polysilicon heater to further reduce heat losses was numerically investigated next⁶. The problem using this technique are the limited available oxide film thicknesses achievable. Typically, 1 - 2 micron oxide thicknesses are deposited, maximum obtainable thicknesses are believed to be less than 5 micron. At these thicknesses, benefits of the oxide layer are small, corresponding only to several degree Celsius temperature drop across the oxide layer, depending on temperature boundary conditions assumed⁶.

Thermal insulation through appropriate packaging of the thruster chip was thus investigated. In order to interface with the chip electrically and to provide propellant feed line connections, the chip will be placed into a Kovar chip carrier. An additional layer of insulating material, epoxied between the Kovar carrier and the chip, will cut down heat losses from the chip. Polyimide was used in these calculations, but other insulating materials, such as alumina, may be used as well. Figure 5 shows, to scale, the Kovar-Polyimide-chip set-up. Kovar and polyimide thicknesses of 1/16“ (1.5 mm) were assumed. Epoxy layers were assumed to be 5 mil (1.27 mm) thick. Using this set up, significantly reduced power levels per heater strip were obtained. In the case of the analysis shown in Fig. 6, a 1 W power level per heater resulted in a heater temperature of 108 C. The silicon temperature at the silicon-polyimide interface reaches values of about 100 C, necessitating the selection of special high temperature epoxies. Epoxies with maximum allowable temperatures of 150 C are readily available.

As a result of these calculations, a “bridge” substrate structure using a 1 micron silicon oxide insulating layer was chosen. As mentioned, the silicon oxide layer does

Table 2: Thermal resistances and Strengths for Various Heater Substrate Configurations

Thermal Resistance (C/W)	Max. Stress at 340 kPa internal pressure (MPa)	Dimensions
0.7	N/A	Plane substrate
3.8	8	1000 micron wide, 100 micron thick bridge
2.8		700 micro wide, 100 micron thick bridge
6.9	59	1000 micron wide, 50 micron thick bridge

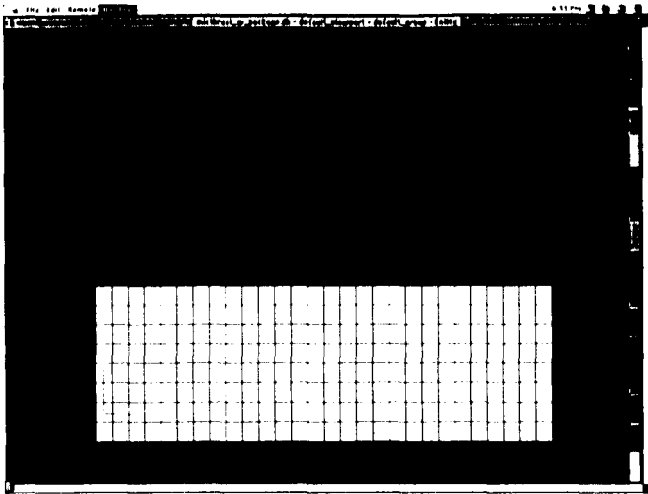

Fig. 5: VLM Packaging Concept and FEA Model

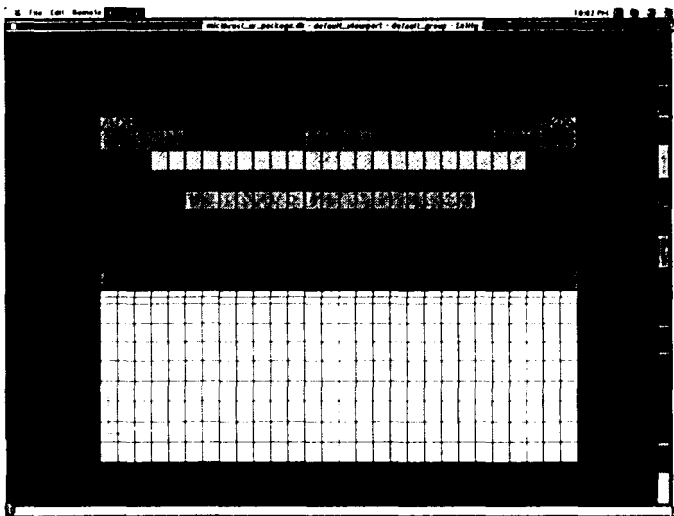

Fig. 6: Example Run of Heat Transfer Analysis for Packaged VLM Configuration

not provide significant thermal insulation, but has to be deposited for microfabrication regions (used as masking materials - see below) and may provide some chemical inertness to otherwise exposed silicon surfaces. The latter consideration gains particular importance when use of such propellants as hydrazine is contemplated. Hydrazine, in particular when heated and used in a 50% water mixture, is considered an etchant for silicon. Kovar mounting structures or alumina chip carriers will be used to provide adequate insulation.

It is unclear at the moment whether a heater temperature of 125 - 150 C will be sufficient to result in heater lengths short enough to be compatible with MEMS

designs. Heat transfer processes in micro-channels are still poorly understood theoretically. Because of this uncertainty, chips with several different heater lengths (3000, 4000, 5000 microns) were designed and built (see below) to study this issue experimentally.

Anodic Bond Testing

The bonded interfaces between the silicon and Pyrex parts of the VLM structure are critical to the reliability of the thruster concept. Since, unlike many other microfabricated devices, a micro-thruster will be subjected to internal pressure, adequate bond strength is required to prevent the thruster body from disintegrating. At the point of the design of the VLM thruster, it was unknown what bond widths would be required to resist the maximum internal design pressure of around 340 kPa (50 psia). Therefore, a series of test chips was fabricated, featuring different size bond widths and subjected to internal pressures until failure occurred to determine bond strengths.

Anodic bonding is used between the silicon and Pyrex (Dow Corning 7740) in the thruster body and thus was used in the fabrication of the pressure test chips as well. Although widely applied in the microfabrication field, the anodic bonding mechanism is still not fully understood. Anodic bonding between silicon and Pyrex is achieved by applying pressure to a silicon and Pyrex piece to provide immediate contact. An electrostatic field is then applied (corresponding to a contact voltage between silicon and Pyrex of 400 to 1200 V) and the temperature of the work pieces is raised to about 400 C. It is believed that a chemical bond in the form of a thin oxide layer forms at the interface. The increased temperature may increase the chemical reaction taking place while the electric field may pull the two work pieces into immediate contact just prior to the actual bonding. However, as mentioned above, the exact bonding mechanism remains a topic of discussion. Nonetheless, operating parameters to achieve this bond are well known and lead to high quality, reproducible bonds.

A series of tests chips as shown in Fig. 7 was fabricated. The silicon piece was subjected to a simple anisotropic etch to leave a flat-topped ridge remaining and enclosing an inner surface of about "4.2 x 4.2 mm. The height of the ridge was about 0.18 mm. Pyrex (7740) was bonded to the silicon at 750 V and about 400 C. The Pyrex thickness was 0.5 mm. The Pyrex piece featured a center, circular inlet hole through which the cavity, enclosed by the silicon ridge and membrane and the Pyrex cover, could be pressurized. The test chips were bonded to an aluminum structure with a alumina sheet placed between the Pyrex and

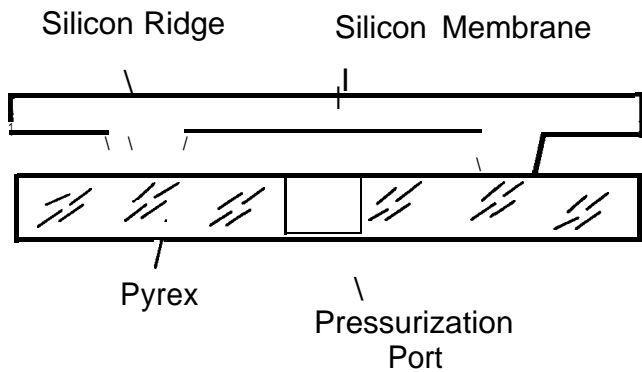

Fig. 7: Concept of Bond Width Test Chip

aluminum to minimize thermal stresses due to differences in the coefficients of thermal expansion (CTE).

Tables 3 and 4 show the results obtained for the tests. Samples having bond widths of 50, 100, and 200 micron were used. Larger bond width samples (500 and 1000 micron bond widths) were fabricated but not used due to the excellent results obtained with the thinner bond width samples. The first set of experiments, results of which are summarized in Table 3, consisted of pressurizing the chips to a specified pressure level and helium leak checking them afterwards. As can be seen, for the 50 micron bond width samples, a large number (3 out of 12 total) started leaking after pressurization up to 100 psig and more failed at higher pressures. At 200 psig, the last two remaining samples leaked as well. For the 100 micron bond width samples, on the other hand, five out of seven samples showed no leaks even after pressurization up to 200 psig. Two samples with a bond width of 200 micron were also subjected to pressurization up to 200 psig and no leak was observed either.

In a second experiment, the remaining samples surviving the 200 psig leak check were temperature cycled at 75 C, 100 C and 125 C. Temperature cycling with temperatures on the order given will be experienced along the bond surfaces of an operating VLM chip. Four 100

Table 3: Leak Check Results of Bond Width Chips

Pressure (psig)	Bond Width (Micron)		
	50 (12 total)	100 (7 total)	200 (2 total)
25		1 leak	
50	1 leak		
100	3 leak		
125	2 leak	1 failed	
150	2 leak		
175	2 leak		
	2 leak	5 No leak	2 No leak

Table 4: Burst Test Results

Sample ID	Bond Width (Micron)	Pressure @ Failure (psig)
73	50	240
91	100	295
92	100	360
93	100	335
94	100	270

micron and one 50 micron bond width sample were used in this test. All samples passed the temperature cycling tests without leakage,

Finally, the samples that survived the temperature cycling tests were subjected to burst pressure tests. The results are shown in Table 4. The first column lists tag numbers identifying each sample for post test analysis. As can be seen, burst pressures, even at these small bond widths, are significant. Values of up to 240 psig for the 50 micron sample and values reaching up to 360 psig with a 100 micron sample were obtained, far exceeding the design limit of 50 psia assumed for the VLM chip, Figs. 8 through 10 show electron microscope scans of one of these test chips after burst (part # 94, 100 micron bond width). Two areas on the chip (identified in Fig 8, and shown in detail in Figs 9 and 10) give an indication of the failure mechanism involved. As can be seen in Fig. 9, the bond separated at some locations along the interface, but not at others. As a result, the ridge structure cracked when the silicon membrane was blown off. In Fig. 10, a shear plane can be identified. On the one side of this plane, the bond detached while it remained intact on the other side. Thus, while bond failure does occur at high pressures, bond strengths, even for relatively small bond widths, are sufficient for use in the vaporizing liquid micro-thruster. In the thruster, due to available space on the chip and for added security, a well over-designed bond width of 3,000 micron was chosen.

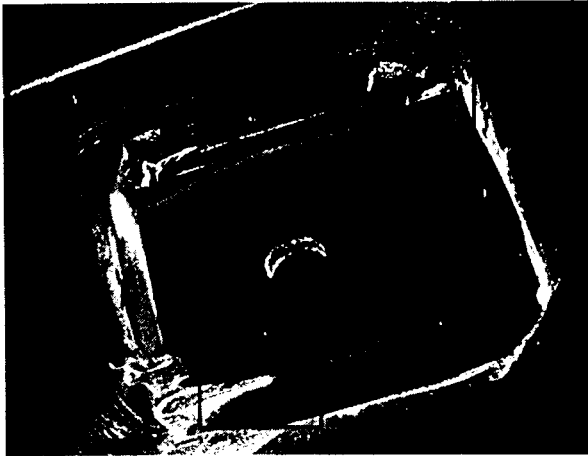

Fig. 8: Bond Test Chip #94 after Burst Test



Fig. 9: Detail of Bond Width Test Chip #94 (Lower Left Corner of Fig. 8), Viewing Direction from Top of Fig. 8.

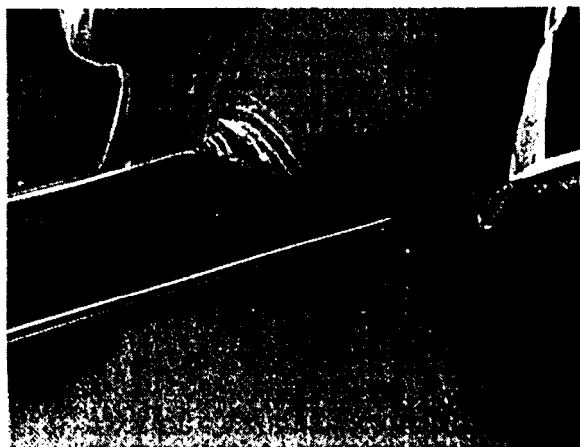

Fig.10: Detail of Bond Width Test Chip #94 (Upper Right Corner of Fig. 8).

Chip Fabrication

Based on the design considerations outlined above, a series of vaporizing liquid thruster chips was fabricated. The silicon portions of the chips were **micromachined** in JPL's Micro Devices Laboratory, with support from Caltech and UCLA for certain fabrication steps. The Pyrex piece was ultrasonically machined by B&B Ultra/Sonic, Inc. in New Jersey. Pyrex of the Dow Corning 7740 type was used due to superior matching of CTES between silicon and Pyrex over the temperature ranges to be encountered for the VLM chip. Pyrex thickness was 0.5 mm.

Three-inch, 600 **micron** thick, 100 silicon wafers were used for fabrication and twenty chips could be placed on each wafer. Due to remaining uncertainties with respect to the required heater length, thrusters with 3000, 4000 and 5000 micron long heater strips were machined on cash wafer. **Polysilicon** was used as the heater material, although metal heaters were fabricated as well (Au, Al) for test pieces. An oxide layer with an approximate thickness of 1 micron was deposited onto the silicon substrate prior to depositing the **polysilicon** heater. This oxide layer was used as masking material to machine the nozzle and two vias for electric contacting of the heater strips. Even though the oxide layer was found to provide no huge contribution to reducing the thruster heat losses, it was left on the chip since it has the potential to provide protection against chemical attack of the silicon by certain propellants possibly used in the future (e.g. **hydrazine**).

The bridge configuration was changed slightly from the ones defined in the FEA calculations above. The thickness of the bridge is now 300 micron in the first generation of chips. The reason for this increase is a simplification of the fabrication procedures as a result of it. Both nozzles and recesses to form the bridge are machined in a single step. In order to form the diverging/converging nozzle, the chip is etched from both sides simultaneously. After etching through half of the wafer from each side, the diverging and converging nozzle sections meet at the center plane of the silicon wafer. At that point in time, the recess has also been machined to exactly one half of the wafer thickness, or 300 micron, leaving a 300 micron bridge structure for a 600 micron thick wafer. This thick a bridge structure will not provide for the same degree of insulation than a 100 micron structure would, but will still provide a heat loss reduction of about 60% over a plain, **uncontoured** silicon substrate. Since heat losses will be cut further due to packaging, the thicker bridge design was considered acceptable at this point. As confidence in the VLM fabrication process increases, thinner bridge structures will

be explored, requiring an additional masking step and careful timing of the etching processes.

One sample of the resulting thruster chip is shown in Fig. 11, with a close-up shown in Fig. 12. The nozzle, heater contact pads and recess are visible in Fig. 12. The heater strip, shown in Fig. 2, is located right underneath the recess area, on the other (internal) side of the silicon chip. Contact pads of both silicon chips are interconnected via conductive epoxy drops placed into the via machined into the Pyrex. Thus, contacting just the upper pads will allow powering of both chip heaters. As can be noted in Fig. 3, showing the nozzle of the chip, some flaking can be observed on the inclined surfaces. This is believed to be due to peeling of the polysilicon film in these areas. It is unclear at this point whether the surface roughness of the nozzle will impact thruster performance. Optimization of performance was not a goal for the first generation of VLM chips. Should future nozzle chips require smoother surfaces, the fabrication procedure may have to be modified to eliminate polysilicon deposition in these areas.

Future Work

With the design program complete and the fabrication phase nearing completion, the VLM chips will be packaged next and then subjected to testing. Initial testing will focus on electric characterization of the chip and include some cycling tests of the conductive epoxy contacting scheme. If feasible, high-speed camera traces will also be obtained to gain a qualitative understanding at what conditions are required for complete propellant vaporization to occur. The preparation of thrust stand tests for the VLM design is currently underway in collaboration with Princeton University. Tests will be performed at both Princeton and JPL. A slightly redefined version of the Princeton thrust stand design is currently being set up at JPL facilities. Special nozzle test chips have been fabricated and will be tested at Princeton shortly. These nozzles are copies of the VLM nozzle design, however, with varying throat dimensions. These nozzles will use cold gas for simplicity. The goal of these tests is to perform check-out tests for the thrust stand at the approximate thrust levels that are being anticipated for the VLM, and to test the unique nozzle design independently from the VLM heater subassembly to determine nozzle performances. Understanding nozzle performances will allow for a more accurate evaluation of heater performances in later VLM tests. These VLM tests are scheduled to be performed this summer at both Princeton and JPL facilities, to obtain initial thruster performance data and evaluate general functionality and feasibility of the VLM concept.



Fig. 11: Completed Vaporizing Liquid Micro-Thruster Chip

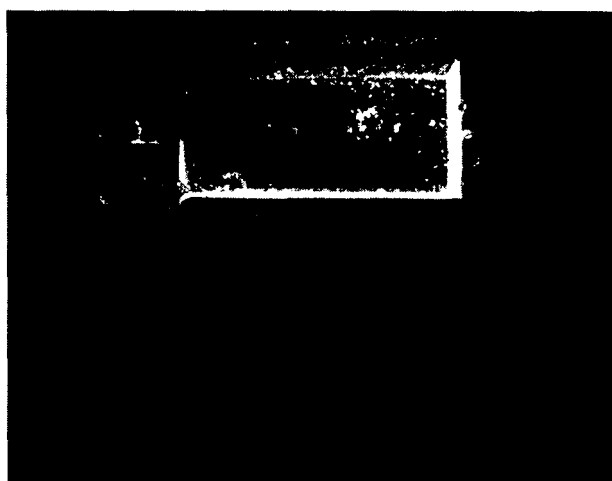

Fig. 12: Detail of VLM Chip showing Nozzle, Recess and Heater Contact Pads.

Conclusions

The design and fabrication of a newly proposed vaporizing liquid (resistojet) micro-thruster (VLM) design was discussed. New generations of very small spacecraft with anticipated masses ranging between 1 - 20 kg, will require new, miniature propulsion systems able to provide primary and attitude control functions. In the attitude control area, thrusts as low as a few MN and impulse bits of 10^{15} Ns or less will be required to for fine pointing and adequate slew maneuvers. Currently existing propulsion hardware, even in the cases of small cold gas thrusters, only marginally meet these microspacecraft requirements or not at all.

The vaporizing liquid micro-thruster is one of the first thruster concepts specifically designed for microspacecraft use. [It makes heavy use of microfabrication

(MEMS) techniques to achieve order-of-magnitude reductions in size and weight, and small impulse bit performances at acceptable trust levels by tailoring nozzle geometries to the dimensions required using these MEMS techniques.

In the first phase of the VLM development program great attention was focused on the proper design of the thruster with respect to thermal management and heat loss control. Silicon is the material of choice in the microfabrication field due to extensive past research and development work done in the area of silicon micromachining. However, silicon also is a very good heat conductor and, thus, its use may lead to excessive heat losses in a resistojet concept. Using finite element techniques, a combination of proper silicon substrate contouring to create thermal chokes, and packaging to provide thermal insulations, was devised. Calculated power levels of only one to a couple of Watts are estimated to raise heater temperatures to values of about 125C. Water for testing purposes, later ammonia and hydrazine, will be used as propellants.

Since the VLM chip consists of an anodically bonded structure, subjected to internal pressures, bond strength characterizations were required. It was found that even for relatively thin bond widths (100 micron) large internal pressures (up to 360 psig burst) could be sustained. Given that the VLM design features bond widths of and in excess of 3000 micron, and internal design pressure values are 50 psia, high reliability of the device is ensured in this regard.

Several chips were fabricated, and more are in assembly. The chips will undergo testing this summer in the near future to determine the degree of vaporization obtainable and determine initial thruster performances.

Acknowledgments

The authors would like to acknowledge the support of Mr. Jim Kulleck in performing various inspection and SEM imaging activities. We especially thank Mr. Ross Jones for supporting this activity through the JPL's Microspacecraft Development Program, Phase 11.

The work described in the paper was conducted at the Jet Propulsion Laboratory under contract with the National Aeronautics and Space Administration.

References

- ¹Mueller, J., "Thruster Options for Microspacecraft: A Review and Evaluation of Existing Hardware and Emerging Technologies, AIAA Paper 97-3058, Seattle, WA, July 1997.
- ²Proceedings, JPL Micropropulsion Workshop, JPL, Pasadena, CA, April 7-9, 1997, to be published.
- ³Mueller, J., Leifer, S. D., Muller, L., and George, T., "Liquid Vaporizing Thrusters", NASA Tech Brief, Vol. 21, No. 5, 1997, pp.73.
- ⁴Peterson, K., "Silicon as a Mechanical Material", Proceedings of the IEEE, Vol. 70, No. 5, pp. 420-457, May 1982.
- ⁵Nakazono, B., "Second-Generation Microspacecraft Propulsion Analysis and Alternatives", JPL Internal Document, JPL-D-14038, Nov. 8, 1996.
- ⁶Wallace, A. P., "Thermal/Stress Analysis Applied to The Design and Packaging of a Vaporizing Liquid Microthruster", Elsevier, to be published.
- ⁷Declercq, M. J., Gerzberg, L., and Meindl, J. D., "Optimization of the Hydrazine-Water Solution for Anisotropic Etching of Silicon in Integrated Circuit Technology", J. Electrochem. Soc., Vol. 122, No. 4, pp. 545-552, April 1975.
- ⁸Ko, W. H., Suminto, J.T., and Yen, G. J., "Bonding Techniques for Microsensors", Micromachining and Micropackaging of Transducers, edited by C.D.Fung, P.W. Cheung, W.H. Ko and D.G. Fleming, Elsevier Science Publ., Amsterdam 1985, p. 41-61.